



Bag Filter Vessels



FSI Advanced Design

FSPN-2500 Shown with
Clam Shell Pneumatic
Lid Lifter



FSI Bag Filter Vessels are designed, built and stamped to meet code requirements in our own ASME code manufacturing facilities. Features like the single-gasket seal, permanent piping and sturdy perforated metal baskets as standard equipment provide durable and consistent performance. Positive bag hold down is an integral part of the lid. Our advanced basket design eliminates the need for under-basket gaskets. Swing-out cover bolts with eyenuts simplify the bag changing operation, while our (optional) Displacement Floats reduce spillage and ensure proper seating of the bag.

Of course, all FSI Bag Filter Vessels are fully compatible with conventional ring type bags as well as FSI Polyloc® bags, which feature the most advanced sealing device on the market today.

Standard Features

- Completely cleanable; easy cleaning access
- Full ports for unrestricted flow
- Sturdy baskets standard (no gasket required)
- Single gasket lid seal
- Positive bag sealing
- Carbon Steel or 304 SS housing standard; 316 SS available on request

Options

- Titanium, Hastelloy B&C, and Alloy 20 available on request
- Coatings available
- Heavy duty baskets available
- Additional connections including Sanitary Fittings and Socket Weld are available

STANDARD FILTER VESSELS

Model No.	No. of Bags	Bag Size No.	Surface Area Per Bag, Ft. ²	Surface Area Per Vessel, Ft. ²	Inlet & Outlet Size	Max Flow Rate, GPM*
FSPN-20	1	3	0.5	0.5	1"	25
FSPN-35	1	4	1.0	1.0	1"	45
FSPN-40	1	1	2.0	2.0	2"	90
FSPN-85	1	2	4.4	4.4	2"	200
FSPN-250	2	2	4.4	8.8	3"-4"	400
FSPN-252	2	2	4.4	8.8	3"-4"	400
FSPN-355	3	2	4.4	13.2	3"-6"	600
FSPN-800	4	2	4.4	17.6	4"-6"	800
FSPN-1000	5	2	4.4	22.0	4"-8"	1000
FSPN-1100	6	2	4.4	26.4	4"-8"	1200
FSPN-1300	7	2	4.4	30.8	6"-8"	1400
FSPN-2000	8	2	4.4	35.2	6"-8"	1600
FSPN-2200	9	2	4.4	39.6	6"-8"	1800
FSPN-2500	10	2	4.4	44.0	6"-8"	2000
FSPN-3000	12	2	4.4	52.8	8"-10"	2400
FSPN-3500	14	2	4.4	61.6	10"-12"	2800
FSPN-4000	16	2	4.4	70.4	10"-12"	3200
FSPN-4200	18	2	4.4	79.2	10"-14"	3600
FSPN-4500	20	2	4.4	88.0	10"-14"	4000
FSPN-4800	22	2	4.4	96.8	10"-14"	4400
FSPN-5000	24	2	4.4	105.6	10"-14"	4800

*Maximum flow rate is based on aqueous flow at 1.0 PSI ΔP clean. Inlet and outlet pipe sizes can be changed to meet customer requirements.

STANDARD EASY OPEN LID VESSELS

Model No.	No. of Bags	Bag Size No.	Surface Area Per Bag, Ft. ²	Surface Area Per Vessel, Ft. ²	Inlet & Outlet Size	Max Flow Rate, GPM*
FSPZ-800	4	2	4.4	17.6	4"-6"	800
FSPZ-1000	5	2	4.4	22.0	4"-8"	1000
FSPZ-1100	6	2	4.4	26.4	4"-8"	1200
FSPZ-1300	7	2	4.4	30.8	6"-8"	1400
FSPZ-2000	8	2	4.4	35.2	6"-8"	1600
FSPZ-2200	9	2	4.4	39.6	6"-8"	1800
FSPZ-2500	10	2	4.4	44.0	6"-8"	2000
FSPZ-3000	12	2	4.4	52.8	8"-10"	2400
FSPZ-3500	14	2	4.4	61.6	10"-12"	2800
FSPZ-4000	16	2	4.4	70.4	10"-12"	3200
FSPZ-4200	18	2	4.4	79.2	10"-14"	3600
FSPZ-4500	20	2	4.4	88.0	10"-14"	4000
FSPZ-4800	22	2	4.4	96.8	10"-14"	4400
FSPZ-5000	24	2	4.4	105.6	10"-14"	4800

*Maximum flow rate is based on aqueous flow at 1.0 PSI ΔP clean. Inlet and outlet pipe sizes can be changed to meet customer requirements.

Polyloc snap tight bag seal

Permanent piping
(in-line models available)

Hinged cover and swing-out bolts with eyenuts

Single-gasket seal

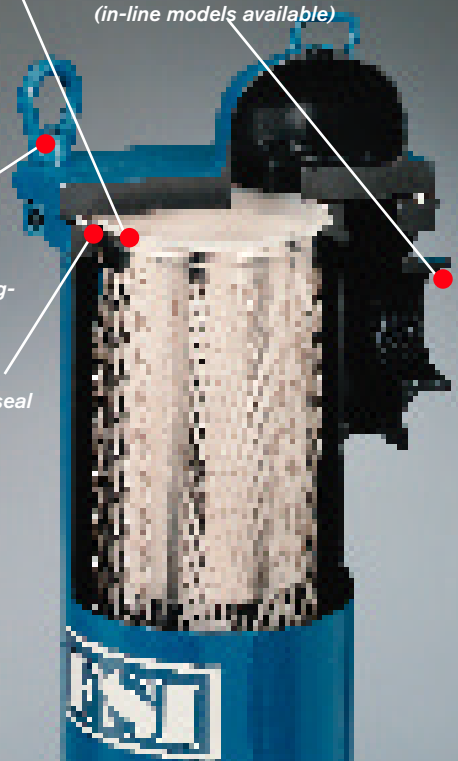

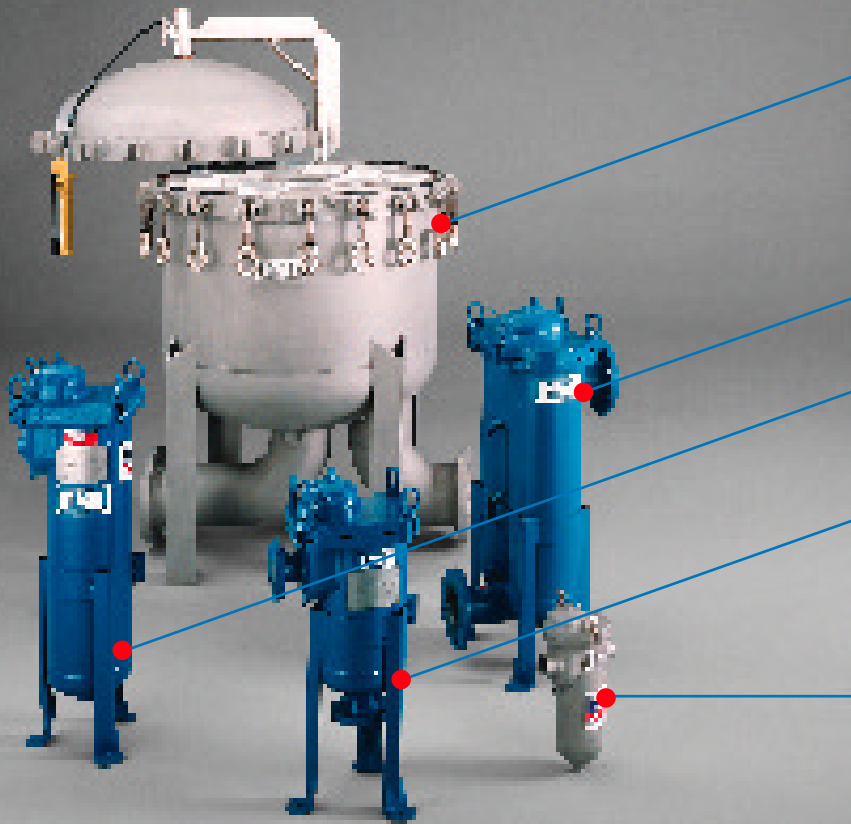

FSPN-3500 Available in standard in-line configuration (shown) or side outlet. Custom styles available on request. Features single-gasket seal, easy access cleaning and sturdy baskets. Uses 14 size 2 filter bags. Hydraulic lid lifter is recommended on 14 bag vessels and larger.

FSPN-250 Features single-gasket seal and sturdy baskets. Uses two size 2 filter bags.

FSPN-85 Uses one size 2 bag. Our most popular vessel. Ideal for batch or continuous applications in paint and resin plants.

FSPN-40 Up to 4" full port that permits non-restricted flow. Side in, bottom out design shown; other outlet configurations available. Designed for continuous flow or small batch operations. Uses one size 1 filter bag. Shown with optional adjustable legs.

FSPN-35 Miniature single bag filter vessel designed for continuous flow or small batch operations. Uses one size 4 bag.

See back cover for ordering information.

BFN Vessels: Your Cost Effective Alternative

FSI, the acknowledged leader in liquid bag filtration equipment, is pleased to offer its new BFN Series bag filter vessels for quality filtration in economical applications.

BFN vessels are available in Carbon Steel and 304 SS; 316 SS available on request.

Standard Features

- Maximum working pressure BFN 11, 12-150 PSI, BFN 13, 14-150 and 300 PSI
- Single gasket cover seal
- Gasket materials available include BUNA N, Neoprene EPR, Viton, Viton Teflon Encapsulated (others on request)
- 304 SS perforated basket for up to 75 PSI differential
- Two inlet/outlet configurations
- Same side inlet/outlet for easy manifolding
- Low pressure drops
- Variety of connections available in either NPT or flange
BFN 11, 12-1", 1 1/4", 1 1/2", 2", 2 1/2", 3", 4"
BFN 13, 14-1", 1 1/4", 1 1/2", 2"
- Permanently piped housing
- Available with extra length legs, evacuation float

Options

- Heavy duty baskets available
- Additional connections including Sanitary Fittings and Socket Weld are available
- BFN 11, 12 ASME code versions available

BFN VESSELS

Model No.	No. of Bags	Bag Size No.	Surface Area Per Bag, FL2	Standard Inlet/Outlet	Max GPM*
BFN 11	1	1	2.0	2"	100
BFN 12	1	2	4.4	2"	220
BFN 13	1	3	0.5	1"	25
BFN 14	1	4	1.0	1"	45

*Maximum flow rate is based on aqueous flow at 1.0 PSI ΔP clean through vessel only without bags installed.

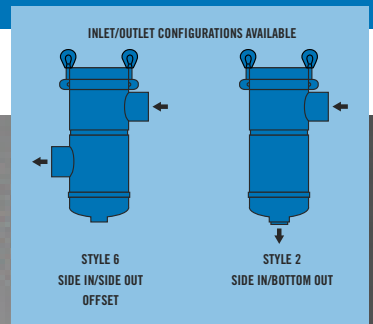

Ordering Information

To order, use the abbreviations from the charts shown on this page.
The charts are color coded for your convenience.

Single Bag Example



These codes describe the following vessel: FSPN-85 Model No. - 304 SS construction - 150 PSI pressure rating - 2" flange connection - Inlet/Outlet Style 2, Side in/Bottom out - Coated

Multi Bag Example



These codes describe the following vessel: FSPN-2500 Model No. - Carbon Steel construction - 150 PSI pressure rating - 8" flange connection - Inline Inlet/Outlet - 1/16" corrosion allowance

BFN Example



These codes describe the following vessel: BFN model series - Polyloc bag style - holds one size 2 bag - 304 SS construction - 150 PSI pressure rating -

SINGLE BAG

1 Model No.	5 Inlet/Outlet Configuration
FSPN-20 FSPN-35	1 - Side In/Side Out - Inline 2 - Side In/Bottom Out 6 - Side In/Side Out - Offset
FSPN-40 FSPN-85	1 - Side In/Side Out - Inline 2 - Side In/Bottom Out 3 - Side In/Bottom Out - 90° Elbow
2 Matl. Of Const.	3 Pressure Rating
CS - Carbon Steel 304 - 304 Stainless Steel 316 - 316 Stainless Steel	150 - 150 PSI 300 - 300 PSI XXX - Customer Specified
4 Connection Size and Type	
FSPN-20 & FSPN-35	
1 NPT 1 1/4 NPT	1 1/2 NPT 2 NPT
FSPN-40 & FSPN-85	
1 NPT 1 1/4 NPT 1 1/2 NPT 2 NPT 2 1/2 NPT 3 NPT	1 FLG 1 1/4 FLG 1 1/2 FLG 2 FLG 2 1/2 FLG 3 FLG 4 FLG
6 Options	
CA - Corrosion Allowance Coated PSJ - Partial Jacket FSJ - Full Jacket	

MULTI BAG

1 Model No	4 Connection Size
FSPN-250 FSPN-252 FSPN-355 FSPN-800 FSPN-1000 FSPN-1100 FSPN-1300 FSPN-2000 FSPN-2200 FSPN-2500 FSPN-3000 FSPN-3500 FSPN-4000 FSPN-4200 FSPN-4500 FSPN-4800 FSPN-5000	3" - 4" FLG 3" - 4" FLG 3" - 6" FLG 4" - 6" FLG 4" - 8" FLG 4" - 8" FLG 6" - 8" FLG 6" - 8" FLG 6" - 8" FLG 8" - 10" FLG 8" - 10" FLG 10" - 12" FLG 10" - 12" FLG 10" - 14" FLG 10" - 14" FLG 10" - 14" FLG
2 Matl. of Const.	3 Pressure Rating
CS - Carbon Steel 304 - 304 Stainless Steel 316 - 316 Stainless Steel	100 - 100 PSI 150 - 150 PSI 300 - 300 PSI XXX - Customer Specified
5 Connection Type	6 Options
Inline Side Out	CA - Corrosion Allowance Coated PSJ - Partial Jacket FSJ - Full Jacket

BFN

1 Model No	2 Bag Style
BFN	P - Polyloc S - Snap Ring
3 No. of Bags	7 Inlet/Outlet Configuration
11 = (1) #1 12 = (1) #2 13 = (1) #3 14 = (1) #4	2 - Side In/Bottom Out 6 - Side In/Side Out - Offset
4 Matl. of Const.	5 Pressure Rating
CS-Carbon Steel 304 - 304 Stainless Steel 316 - 316 Stainless Steel	150 - 150 PSI 300 - 300 PSI
6 Connection Size and Type	
1 NPT 1 1/4 NPT 1 1/2 NPT 2 NPT 2 1/2 NPT 3 NPT	1 FLG 1 1/4 FLG 1 1/2 FLG 2 FLG 2 1/2 FLG 3 FLG 4 FLG

FSI's "comprehensive manufacturing control" philosophy ensures that we will maintain our status as the industry leader in all phases of the filter business. For more information, technical consultation or details about our design capability, contact your FSI representative or our headquarters in Michigan City, Indiana.



Filter Specialists, Inc.

ISO CERTIFIED

TO LEARN MORE ABOUT FILTER SPECIALISTS PRODUCTS, CONTACT ONE OF THE OFFICES OR VISIT OUR WEBSITE AT: <http://www.fsifilters.com>

USA
FILTER SPECIALISTS, INC.
SHIP: 100 Anchor Road
Michigan City, IN 46360
MAIL: P. O. Box 735
Michigan City, IN 46361
Phone: 219-879-3307
800-348-3205
Fax: 219-877-0632

Europe
FILTER SPECIALISTS INTERNATIONAL GMBH
Balterweg 3.1
D-65817 Eppstein-Bremthal
Germany
Phone: 011-49-6198-58080
Fax: 011-49-6198-580815

Central America
FSI de MEXICO
S. de R.L. de C.V.
Centeno 119-A
Granjas Esmerelda
Iztapalapa, Mexico D.F. C.P. 09810
Phone: 011-52-5-670-2224
Fax: 011-52-5-670-6068

South America
FSI SUL AMERICANA INDUSTRIAS
Rua Oneda
671 Bairro Planalto
Sao Bernardo Do Campo
Sao Paulo, Brazil
Cep 09895-280
Phone: 011-55-11-4341-6840
Fax: 011-55-11-4341-6464

There are no expressed or implied warranties, including the implied warranty of merchantability and fitness for a particular purpose not specific herein respecting this agreement or the product being sold hereunder or the

BFV-015-1001
Part No.: RMLBFVR