

INSTALLATION,
OPERATION AND
MAINTENANCE
MANUAL



FILTER VESSELS

This manual contains
important revised
information and
supersedes all prior
publications.

IMPORTANT!
READ AND
UNDERSTAND
ENTIRE MANUAL
BEFORE OPERATING
THIS VESSEL

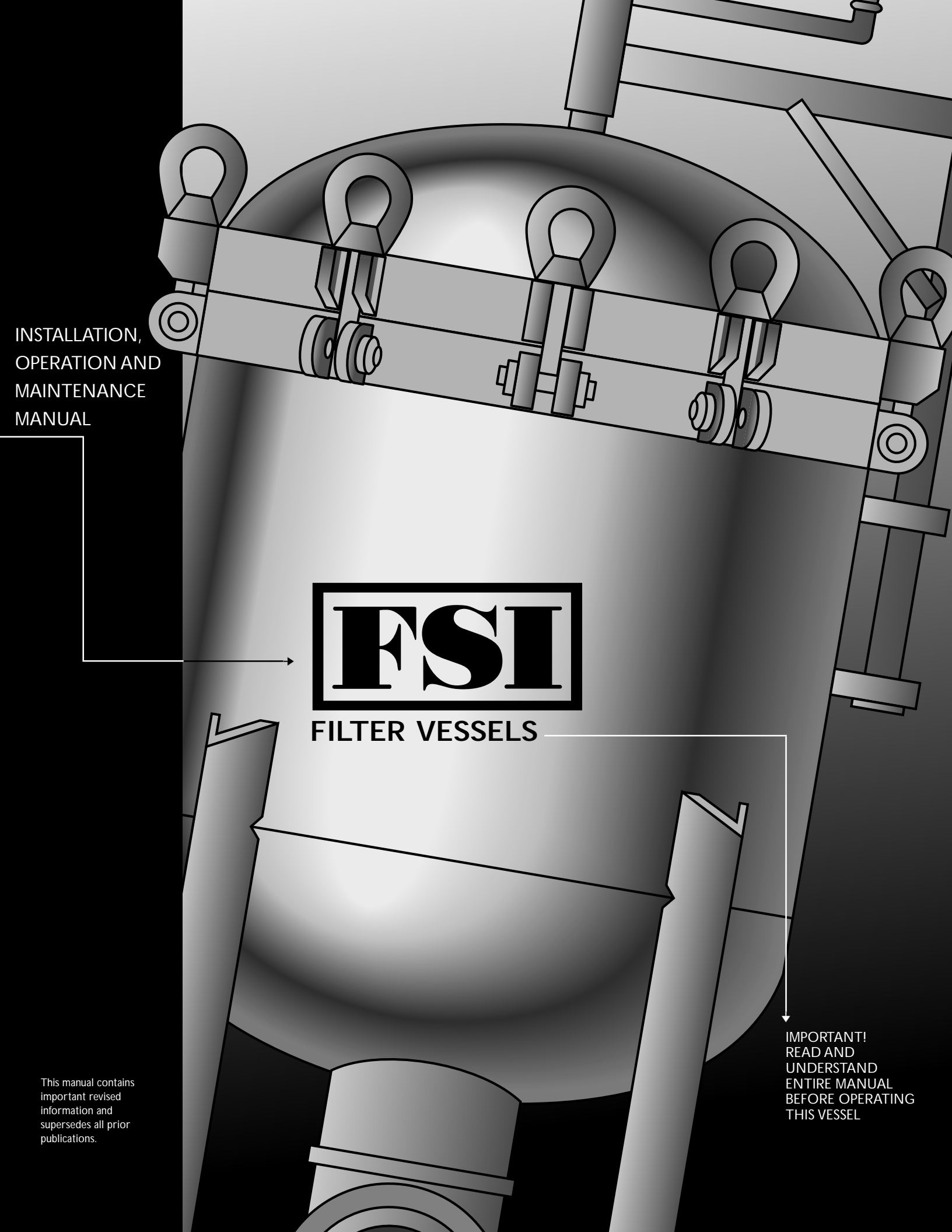

SAFETY

This manual has been prepared for the safe installation, operation, and maintenance of FSI pressure vessels. Warning labels have been reprinted in this manual. The application of warning labels to vessels is based upon vessel type and adequate space to affix labels. **Warning labels are not a substitute for reading and understanding this manual.**

LABEL FORMAT

- A. Hazard Alert Word
- B. Hazard and Consequence Statement
- C. Instruction Statement

A. →  **WARNING!**

B. → Improper use of this vessel can cause serious injury, blindness or death.

C. → Read the vessel ASME code plate, warning labels and this instruction manual for the installation, operation and maintenance of filter vessels before installation and operation.

All labels must be replaced when legibility is lost or visibility is blocked. Labels have a part number in the lower right hand corner for reordering.

PROTECTIVE CLOTHING

Before operating this vessel, operator should wear protective clothing including protective gloves and face shield. If handling hot liquids, operator should wear heat-resistant clothing such as Nomex garments to prevent possible burning or scalding. Refer to Material Safety Data Sheet (MSDS) for specific instructions for handling the liquid as supplied by the manufacturer of the material.

INSTALLATION

MOVING VESSEL

- A. Mount vessel securely to a skid and move skid with fork lift.
- B. Vessel can be lifted by means of a multi-legged sling chain with a safety hook attached to the end of each leg. Attach the hook of each leg to an eyenut and space legs around vessel equally. (See Figure 1)

PLACEMENT OF MANUAL FOR THE INSTALLATION, OPERATION AND MAINTENANCE OF FILTERVESSELS

The end user is to locate one manual for the installation, operation, and maintenance of filter vessels on each vessel at final installation so it is visible and accessible to an operator.

MOUNTING

All vessels must be properly bolted to the floor before moving the lid. This will assure vessel stability and prevent tipping.

NEW FLOOR CONSTRUCTION

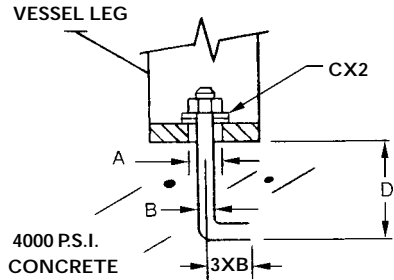

EXISTING CONCRETE FLOOR

For vessels placed on existing floors, use the following or an equivalent:
 Red 1 – Chem-threaded anchor rod
 Red 1 – Chem capsules

Refer to manufacturer's literature for part number and installation instructions.

ITW Ramset/Red Head
 U.S. 12 & Liberty Trail
 Michigan City, IN 46360
 Phone Number: (219) 874-4217
 Fax Number: (219) 874-7035

For vessel weight, check the bill of lading.

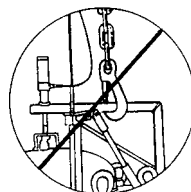
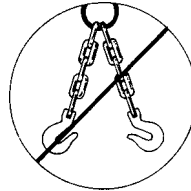
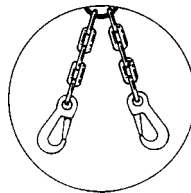

⚠ WARNINGS

Never use the lid support arm to lift vessel.

Damage to lift assembly will result.

Vessel may drop.

Two-legged sling for vessels with 2 or 4 eyenuts.

FIGURE 1

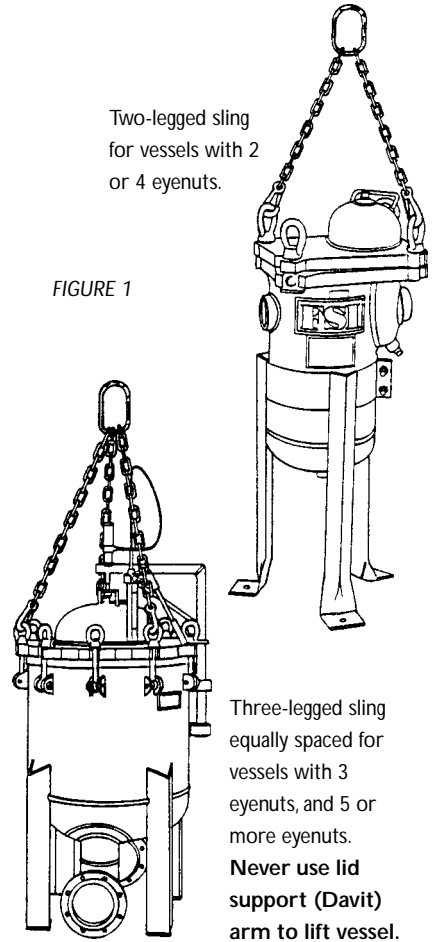

Three-legged sling equally spaced for vessels with 3 eyenuts, and 5 or more eyenuts. Never use lid support (Davit) arm to lift vessel.

A	B	C			D	
Mounting Plt. Hole Diameter	Anchor Thread Diameter	American Standard Plane Washer			Embedment	Minimum Pullout
		ID	OD	THK		
17/32 in 13.4 mm	3/8 9.5	7/16 11	1 25.4	.10 2.5	3 76	4000 lb 1814 kg
1 in 25.4 mm	1/2 12.7	9/16 14.3	1-3/8 34.9	.13 3.3	4 101	7500 lb 3402 kg

INSTALLATION

PIPING

The piping material used should be the same as the base material of the vessel. It should have a rating equal to or greater than the pressure and temperature rating of the vessel.

RELIEF VALVE

It is the responsibility of the end user to protect system components, such as the FSI Filter, from being over pressurized. This can be achieved by installing a system relief valve.

PRESSURE GAUGE, TEMPERATURE GAUGE, AND VENT VALVE

FSI does not supply the vessel pressure gauge, temperature gauge, or the vent valve. It is the responsibility of the end user to obtain, install and maintain the proper gauge, indicating vessel temperature and internal vessel pressure. (Refer to Figure 2, Page 5)

GASKET

Note: The operating temperature of a gasket material changes with respect to the fluid temperature and chemical concentration.

Each FSI gasket is labeled to show the vessel type it will fit and the gasket material.

LABEL FORMAT

EXAMPLE:

VESSEL TYPE →	FS 3500, 3000, 2500, 30021 FSP 4000
GASKET MATERIAL →	Viton®

SPECIAL INSTRUCTION LABELS

Gasket installed with lips toward center of vessel.



Use only FSI approved gaskets.

SYSTEM CHECK

It is advisable to hydro-statically test this vessel with water to determine if there are any leaks in the system.

Should there be any questions or if assistance is needed in the installation, operation or maintenance of this vessel, please contact the Engineering Department, Filter Specialists, Inc., P.O. Box 735, Michigan City, IN 46360. Phone: 800-348-3205 Fax: (219) 877-0639

⚠ WARNINGS

Gaskets can fail, causing serious injury and/or blindness.

Gasket material must be chemically and temperature compatible with fluid being filtered.

MAINTENANCE

MANUAL LIFTING DEVICE:
Refer to Figure 2

This device consists of a threaded stud (Item 16) welded to the lid and an internally threaded crank handle (Item 15).

A. Keep threads clean and well lubricated with a lubricant acceptable for the customer's application.

B. Threads should be inspected periodically for wear and tear. Should the wear become excessive, parts should be replaced with authorized FSI parts.

CRANK HANDLE – P/N 26004
Specify carbon steel OR stainless steel vessel

***THREAD STUD – P/N 20521**
Specify carbon steel OR stainless steel vessel

C. Lubricate the support and swivel blocks (Item 14) of the Davit Arm which supports the lid when opened.

HYDRAULIC LIFTING DEVICE:
Refer to Figure 2

FSI offers three basic lid lifting cylinder assemblies. See Table 1 for replacement parts.

A. Maintain the hydraulic reservoir in the dump (Item 12) with hydraulic fluid. Refer to the manufacturer's maintenance literature (See Pages 6-7). The pump relief valve is factory set to prevent excess pressure (1800 PSI).

B. Check the hydraulic hoses (Item 13) periodically for tears, abrasion and kinks. Replace if needed.

C. There are two (2) nuts attached to the end of the cylinder rod. The first is a jam nut (GR5) (Item 10) and the second is a lock nut with a nylon insert (Item 11). If item 11 is removed, it must be replaced with a new one to keep it from vibrating loose.

D. On the lift cylinder assemblies, the lid lowering rate can be set by

adjusting the flow control valve mounted in the cylinder end cap. Adjust speed so that the lid comes down slowly. (Item 19, Figure 2)

*Threaded stud must be welded by an authorized ASME code weld facility. The vessel must be re-inspected after welding by an authorized inspector.

TABLE 1 REPLACEMENT PART LIST FOR LID-LIFTING DEVICE

General application for vessels rated at 150 PSI or less and NO corrosion allowance. Please have FSI verify the actual lift cylinder assembly by matching it with the vessel serial number for all other vessels.					Grade #5	
MODEL NO.	LIFT CYLINDER ASSEMBLY PART NO.	HYDRAULIC PUMP PART NO.	HYDRAULIC HOSE PART NO.	HYDRAULIC CYLINDER PART NO.	LOCK NUT	LOCK NUT WITH NYLON INSERT
252-3500	19982	26220	26222	3/4 BORE X 3 STK # 26010	1/4-28 # 25115	1/4-28 # 25116
4000-5000	402184	26221	26222	1-1/8 BORE X 3 STK # 26218	3/8-24 # 25117	3/8-24 # 25118
5500 and up	404342	26221	26222	1-3/8 BORE X 3 STK # 26209	# 25117	# 25118

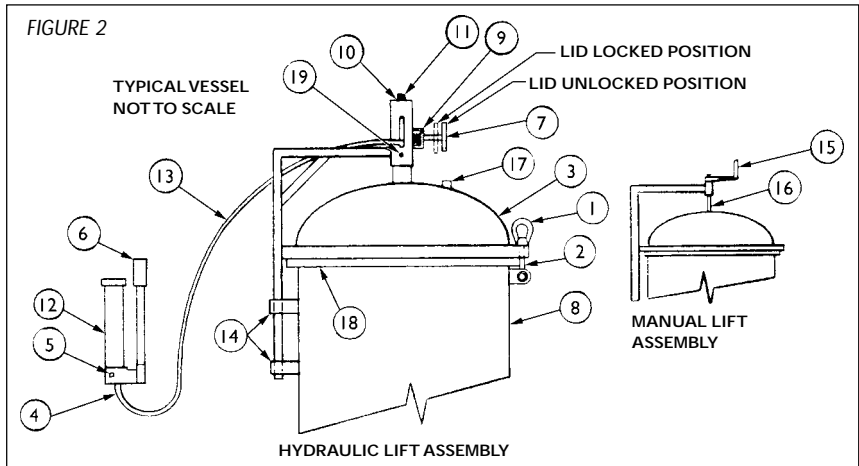

ITEM	DESCRIPTION	ITEM	DESCRIPTION
1	Eye Nut	11	Lock Nut
2	Lid Restraining Bolts	12	Hand Pump
3	Lid	13	Hose
4	Pump Hose End	14	Support Blocks Davit Arm
5	Pump Release Valve	15	Handle
6	Pump Handle	16	Stud
7	Safety Pin	17	Vent
8	Vessel Body	18	Collar Plate
9	Spring	19	Flow Control Valve in Cylinder End Cap
10	Jam Nut		

OPERATION

REMOVAL OF AIR

When hoses, cylinders and other components are connected to build a system, air will be trapped in the system. To function properly, the air in the system must be removed. However, the hand pump does require air in the reservoir to prevent a vacuum. If the pump reservoir is totally filled and the vent cap is closed tight, the vacuum created will prevent oil flow out of the pump. Fill reservoirs only to level indicated on the pump end cap.

SINGLE ACTING CYLINDER SYSTEMS

1. After all system components are connected to the hand pump, check reservoir oil level. Fill to indicator mark on the end cap. Replace the fill cap and be sure it is closed (not in vent position).
2. Turn pump release valve to closed position. Operate hand pump until cylinder plunger is completely extended.
3. Invert cylinder (plunger end down). Open the pump release valve; as the plunger retracts, the air in the system will be forced into the pump reservoir and replaced by oil. Close the release valve.
4. Turn the cylinder upright. Operate the pump to cycle the cylinder plunger. If air is out of the system, the plunger will advance and retract smoothly. If the plunger is erratic, repeat steps 1 through 4.
5. Open the pump fill cap and check the oil level. Fill to the indicator mark on the end cap.

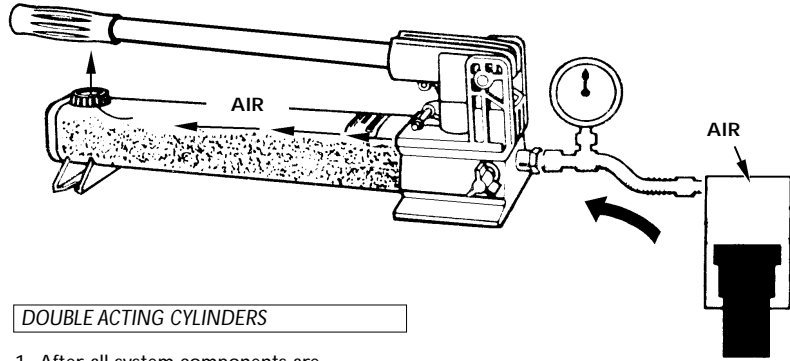

DOUBLE ACTING CYLINDERS

1. After all system components are connected to the hand pump, check pump reservoir oil level. Fill to the indicator mark on the pump end cap. Replace end cap and tighten (not in vent position).
2. Place hand pump in a place where it will be higher than the hydraulic cylinder. Lay the hydraulic cylinder on its side with the couplers facing up.
3. Close the pump release valve (finger tight). Operate the pump to advance and retract the cylinder plunger three or four times.
4. Open pump release valve to retract the cylinder plunger. Check pump oil level. Add oil as necessary to restore correct level in the reservoir.

4. Pump can be operated from horizontal or vertical (as long as hose end is down).

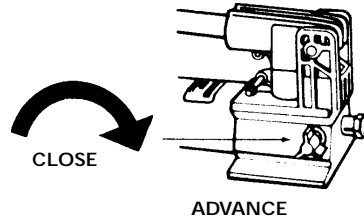
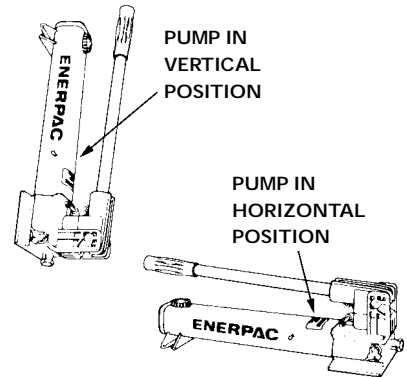

1. To advance cylinder plunger, turn pump release valve clockwise as illustrated and close fingertight. CAUTION: To avoid release valve damage, do not use tools to tighten valve.
2. Operate pump handle.

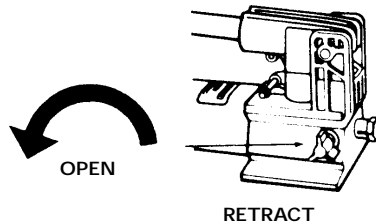

3. To retract cylinder plunger, turn release valve counterclockwise as illustrated.

MAINTENANCE

To check oil level in pump, open pump release valve to allow cylinder (if connected) to return to pump. Remove fill cap. Add ENERPAC hydraulic oil until level with mark on rear cap. **DO NOT** overfill. To function properly, all hand pumps require air in the reservoir. If oil level is too high, the pump will not operate. If hydraulic system is used under extremely dirty conditions, frequently drain pump completely. Refill with clean ENERPAC hydraulic oil. Install fill cap and close it.

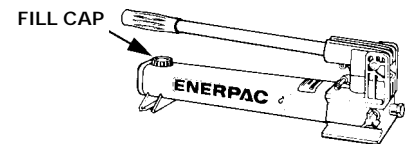
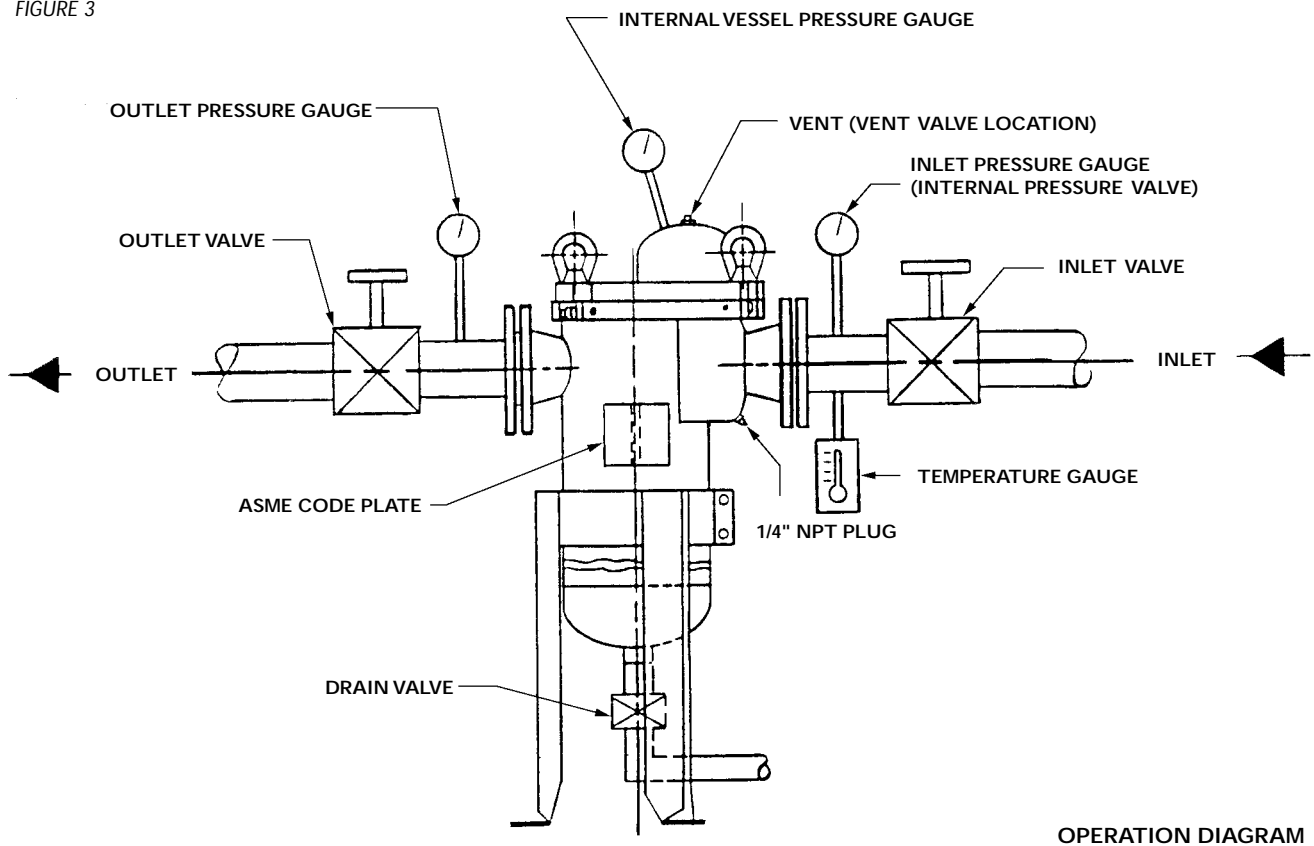

FIGURE 3



REPLACING COUPLER

ASSEMBLING TO HOSE

Clamp the hexagon nut of the hose fitting in a vise as illustrated. Remove the old coupler or rigid adaptor. Install new coupler clockwise on to hose fitting to a firm fit. Use high quality thread sealer on threads (one wrap only). A kit has been prepared for the purpose of replacing a worn out seal and may be obtained at your nearest authorized technical service center.

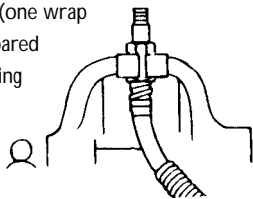

ASSEMBLING SPEED-D-COUPERS TO CYLINDER

Use wrench to unscrew old coupler half from cylinder. Thread new coupler to cylinder and tighten firmly. Use a high quality thread sealant on coupler thread (one wrap only).

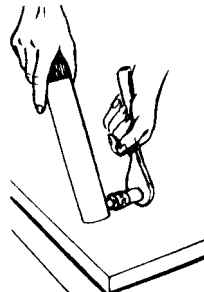

LIDS WITH NO LIFT MECHANISM — lid nuts should be unscrewed far enough to allow the lid to rest on the gasket freely and parallel to the vessel collar plate.

FIGURE 4

NOTE: POSITION OF EYE NUTS PRIOR TO TIGHTENING

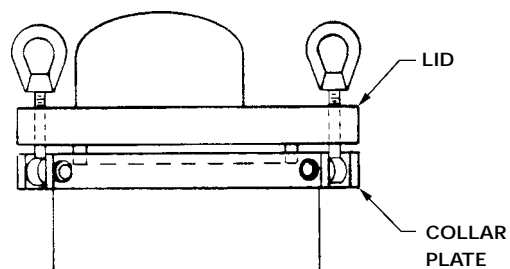

 **WARNING**
Hot and/or chemically active liquids can cause serious injury and blindness.

Before operating this vessel, operator should wear protective clothing, including protective gloves and face shield. If handling hot liquids, operators should wear heat resistant clothing such as Nomex garments, to prevent possible burns.

 **WARNINGS**
Do not exceed the operating limits of this vessel and gasket.
Serious injury or death can result if limits are exceeded.

Refer to the Material Safety Data Sheet (MSDS) for specific information on material. The MSDS is supplied by the manufacturer of the material.

For maximum pressure, check ASME code plate of vessel.

For maximum temperature of vessel, check ASME code plate.

For maximum operating temperature of gasket, call FSI, (219) 879-3307. The maximum gasket operating temperature can change with changes in fluid, chemical composition, temperature and pressure.

Note: Do not exceed the lesser of the two maximum temperatures.

I. INITIAL CLOSING OF THE VESSEL

Vessel must be isolated from system – pump turned off and locked out; inlet and outlet valves closed. Refer to Figure 3, Page 7.

- A. Insert basket into seat. The basket rim flange must cover entire opening. If not, the basket may cock and be forced through the opening under pressure. Refer to Figure 5, Page 9.
- B. Insert new filter elements, making sure that all bags or cartridges are properly seated. Snap ring bags must have the selvage on the inside of the bag to prevent bypass. Refer to Figure 5, Page 9.
- C. Inspect gasket groove and gasket. Refer to Figure 6, Page 10. If gasket is nicked or worn, replace only with FSI replacement parts. For ordering replacements, refer to vessel model number and serial number.
- D. Insert gasket, making sure gasket is not twisted, and if a lip-type gasket is used, the lips must point inward as shown in Figure 6, Page 10. If gasket wants to roll out of groove, stretch gasket slightly by hand, inspect gasket seam, and refit into groove.
- E. Position lid for closing.
 - 1. Lids with no lift mechanism — lid nuts must be unscrewed far enough to allow the lid to rest on the gasket freely and parallel to the vessel collar plate. Refer to Figure 4, Page 7.
 - 2. Lids with a crank—Refer to Figure 3, Page 7.
 - a. Rotate lid over vessel so the eye nut and bolt bracket are in line.
 - b. Turn crank to lower lid.
 - c. Realign brackets, if necessary, before lid sets down on vessel body.
- F. Engage all bolts. Hand tighten nuts. Refer to Figure 7, Page 10.
- G. Moderately torque nuts at 180° to each other, rotating around the vessel until tight. Refer to Figure 7, Page 10.
- H. Close vent valve. Refer to Figure 3, Page 7.
- I. Turn pump on.
- J. Open inlet valve slowly and observe for leaks. Should any leaks appear, close valve immediately and continue with part II. Refer to Figure 2, Page 5.
- K. If necessary, fill vessel with product by evacuating the air via the vent valve.
- L. Open outlet valve. Refer to Figure 3, Page 7.

- 3. Lids with hydraulic lifts—Refer to Figure 2, Page 5.
 - a. Refer to steps E2a, E2b, E2c.
 - b. Hold hand pump in vertical position with hose end down and raise lid slightly.
 - c. With one hand, pull safety pin out to disengage it. Hold in this position.
 - d. With other hand, crack open the pump release valve.
 - e. Lower lid until it almost touches gasket, release safety pin, align eyebolt and eye nut brackets, and continue to lower lid until it rests freely on the gasket.

 **WARNINGS**
A falling lid can cause serious injury and loss of limb.
Never place hands, fingers, or limbs between lid and vessel.

II. OPENING AND CLOSING OF THE VESSEL LID

Adhere to the following sequence. Refer to Figure 2, Page 5.

! WARNING
 Do not open a vessel under pressure.
 Escaping fluid can cause serious injury and blindness.

- A. Before opening vessel:
 1. Turn off pump and lock it out.
 2. Close inlet and outlet valve.
- B. Open vent valve. Make sure that the valve outlet is so piped that escaping fluids are so directed to prevent personal injury of the operator and surrounding area.
- C. Check pressure gauge to make sure that the isolated vessel's internal pressure is zero PSI gauge. Refer to Figure 3, Page 7.
- D. Drain fluid from vessel by gravity flow through drain valve. Close drain valve. Evacuation can be assisted with pressurization. Refer to "Blow Down Procedure," Page 11.

E. Loosen lid nuts and swing nuts and bolts free of lid.

F. Lift lid.

Lids with hydraulic lifts:
 Hold hand pump vertically with hose end down. Close pump release valve and pump until lid lifts high enough to engage spring loaded safety pin.

! WARNING
 Safety pin must be engaged when lid is open.
 A falling lid can cause serious injury and loss of limb.

- G. Rotate lid off of vessel.
- H. Remove filter bag or cartridges with caution.
 - I. Inspect basket for roundness and flange condition.
 - J. Verify that basket and bag-bearing surfaces are clean and free of nicks.
- K. Insert new filter elements, making sure that all bags or cartridges are properly seated. Snap ring bags must have selvage on inside of bag. Refer to Figure 5.

L. Remove gasket; clean gasket groove. If gasket is worn or nicked, replace only with FSI replacement parts. For correct replacements, refer to the vessel model number and serial number. Use only FSI authorized gaskets.

M. Rotate lid over vessel and align bolt and nut brackets.

N. Close lid. Same as E1, E2, and E3, Page 8.

O. Same as I.F.

P. Same as I.G.

Q. Same as I.H.

R. Same as I.L.

S. Same as I.J.

T. Same as I.K.

U. Same as I.L.

If a vessel still leaks, depressurize vessel and retorque bolts according to step I.G., Page 8. If vessel leakage continues, call FSI.

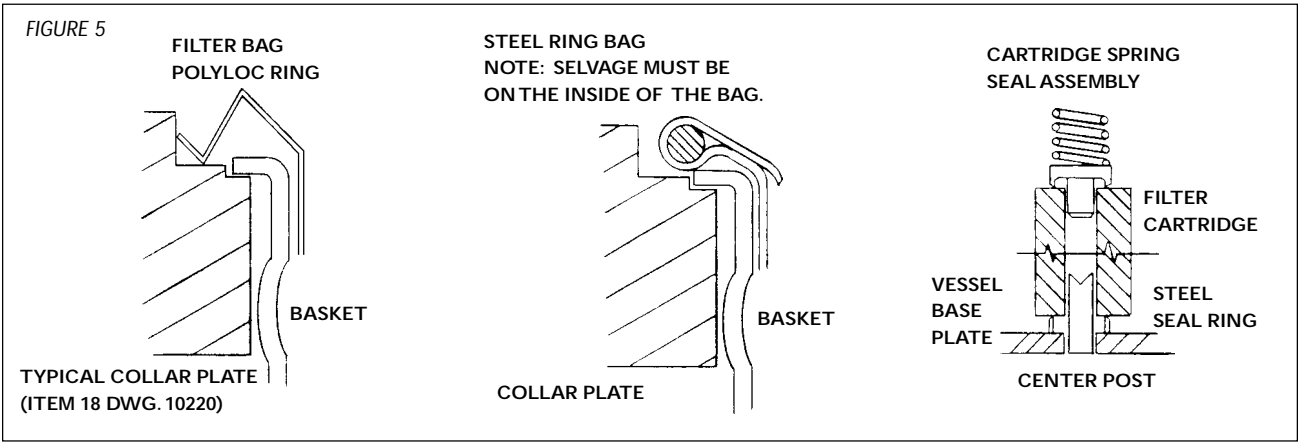

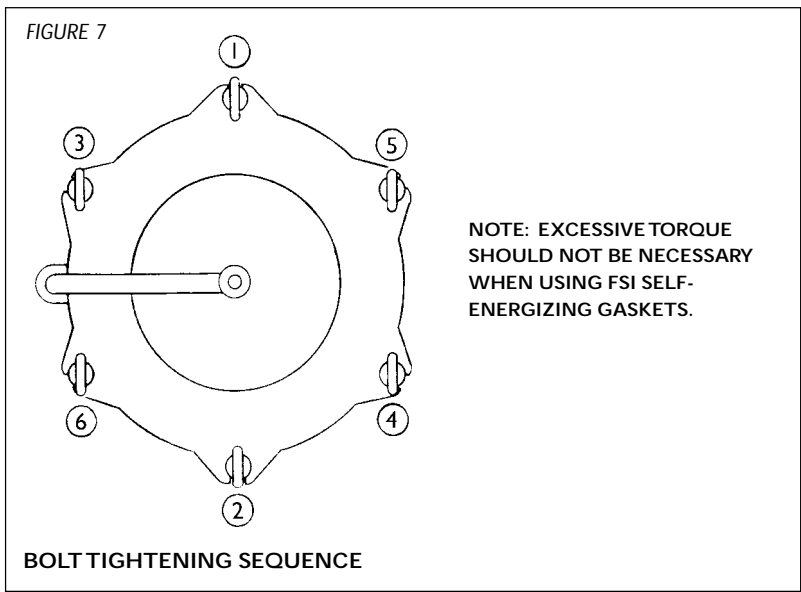
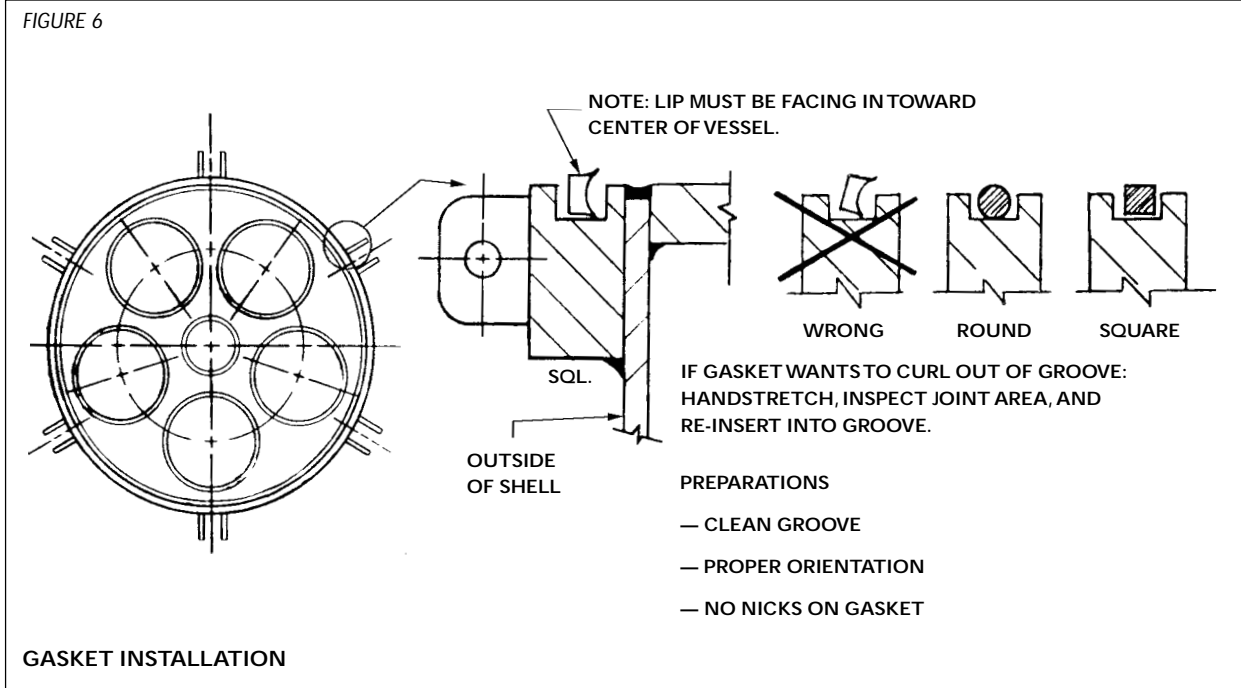

Standard FSI vessels are designed to use gaskets made of self-energizing material, such as BUNA, EPR, or Viton®. The torque requirements to seal a vessel with such gaskets is minimal. It is, therefore, not necessary to use extensions or cheater bars when torquing eye nuts. FSI does not recommend the use of gaskets made of non-energizing material or rope-type gaskets. They may require excessive tightening torque. Due to the many variables that influence torque, exact values are not given herein. For general torque values applicable to your particular vessel, call FSI at 1-800-348-3205.

BLOW DOWN PROCEDURE

To aid filter element changes, the liquid in the vessel can be evacuated prior to the change.

1. Close inlet valve. Refer to Figure 3, Page 7.
2. Close outlet valve.
3. Open vent valve.
4. Check gauge — internal pressure must be zero.
5. Open drain valve.
6. Close vent.
7. Connect gas to vessel via vent valve.
Use only if gravity evacuation does not yield desired results.
8. Open vent valve slowly.
9. Close vent valve metering out fluid.
10. Disconnect gas.
11. Close drain valve.
12. Make sure internal pressure is zero and continue with opening instructions.

FILTER IN OPERATION

Once the filter is operational and in use, the differential pressure should be checked regularly. It is suggested that when the differential pressure across the filter elements reaches a predetermined amount, the elements be changed. If the differential pressure suddenly drops, stop filtration immediately and check bags for proper seal or rupture.



WARNINGS

The gas used for blow down must be stable in the environment of the fluid being evacuated.



WARNINGS

- PRESSURE GAUGE AND VENT VALVE MUST BE INSTALLED IN ACCESS HOLE.
- FAILURE TO INSTALL PRESSURE GAUGE AND VENT CAN RESULT IN SERIOUS INJURY WHEN OPENING THE LID.
- DIRECT VENT VALVE EXHAUST TO A SAFE PLACE.

1289

PT. NO. 35001



WARNINGS

- VESSEL MAY TIP IF NOT PROPERLY BOLTED TO FLOOR.
- A TIPPING VESSEL CAN CAUSE SERIOUS INJURY.
- PROPERLY BOLT VESSEL TO FLOOR BEFORE ROTATING LID.
- REFER TO MANUAL FOR THE INSTALLATION, OPERATION, AND MAINTENANCE OF FILTER VESSELS.

1289

PT. NO. 35002



WARNING!

- VESSEL AND/OR GASKET CAN FAIL IF OPERATING LIMITS ARE EXCEEDED.
- A FAILURE CAN CAUSE SERIOUS INJURY, BLINDNESS OR DEATH.
- DO NOT EXCEED MAXIMUM OPERATING PRESSURE PER VESSEL CODE PLATE.
- CHECK TEMPERATURE RANGE ON VESSEL CODE PLATE.
- CHECK TEMPERATURE RANGE OF GASKET MATERIAL WITH RESPECT TO FLUID BEING FILTERED.
- DO NOT EXCEED THE LESSER OF THE TWO OPERATING TEMPERATURES.
- SECURE LID BY TIGHTENING LID EYENUTS.
- READ THE MANUAL FOR THE INSTALLATION, OPERATION, AND MAINTENANCE OF FILTER VESSELS.

1289

PT. NO. 35000



WARNING!

- RAISED LID MAY FALL IN THE EVENT OF A HYDRAULIC OR MECHANICAL FAILURE.
- A FALLING LID CAN SERIOUSLY INJURE OR CAUSE LOSS OF LIMB.
- REFER TO FSI OPERATING AND MAINTENANCE INSTRUCTIONS.
- READ AND UNDERSTAND THE FOLLOWING INSTRUCTIONS:
 - NO BODY PARTS UNDER THE LID AT ANY TIME.
 - WEAR EYE PROTECTION IN CASE OF HYDRAULIC COMPONENT RUPTURE.
 - ENGAGE LID SAFETY LATCH WHERE APPLICABLE.

1289

PT. NO. 35003



WARNING!

- IF IMPROPERLY USED, THIS VESSEL CAN CAUSE SERIOUS INJURY, BLINDNESS OR DEATH.
- READ ALL WARNING LABELS AND MANUAL FOR THE INSTALLATION, OPERATION, AND MAINTENANCE OF FILTER VESSELS BEFORE USE.
- FOR ADDITIONAL MANUALS, CALL FSI AT 1-800-348-3205.

PT. NO. 35005



WARNING!

- GASKET SEAL MAY LEAK OR SQUIRT FLUID UNDER PRESSURE IF THE LID OPENING AND CLOSING INSTRUCTIONS ARE NOT FOLLOWED.
- SQUIRTING FLUID CAN CAUSE SERIOUS INJURY OR BLINDNESS.
- READ THE MANUAL FOR INSTALLATION, OPERATION, AND MAINTENANCE OF FILTER VESSELS.
- WEAR PROTECTIVE CLOTHING.
- WEAR FACE SHIELD.
- BEFORE OPENING, TURN PUMP OFF AND LOCK IT OUT.
- CLOSE INLET AND OUTLET VALVE.
- OPEN VENT SLOWLY — DIRECT EXHAUST TO SAFE PLACE.
- INTERNAL PRESSURE SHOULD BE ZERO PSI GAUGE.
- DRAIN FLUID VIA DRAIN VALVE.
- CLOSE DRAIN VALVE.
- UNBOLT LID LUGS.
- LIFT LID.
- ENGAGE LID SAFETY PIN (IF APPLICABLE).
- ROTATE LID, UNCOVERING VESSEL.
- CHANGE FILTER ELEMENT.
- REMOVE GASKET, CLEAN GASKET GROOVE AND GASKET.
- INSPECT GASKET GROOVE AND LID SEALING AREA FOR DAMAGE.
- REPLACE DAMAGED PARTS WITH FSI REPLACEMENT PARTS ONLY.
- REPOSITION LID, DISENGAGE SAFETY PIN AND LOWER LID ONTO VESSEL SLOWLY.
- REPLACE WASHERS UNDER NUTS IF NECESSARY.
- ENGAGE ALL BOLTS, HAND TIGHTEN NUTS.
- NUT AND BOLT THREADS MUST BE FREE OF RUST AND FOREIGN MATTER.
- MODERATELY TORQUE NUTS AT 180° TO EACH OTHER, ROTATING AROUND VESSEL.
- CLOSE VENT VALVE.
- ACTIVATE PUMP.
- OPEN INLET VALVE SLOWLY. OBSERVE FOR LEAKS. IF LEAK APPEARS, CLOSE VALVE AND START OVER.
- IF THERE ARE NO LEAKS, OPEN OUTLET VALVES SLOWLY.

1289

PT. NO. 35004

TO LEARN MORE ABOUT FILTER SPECIALISTS, INC. PRODUCTS, CONTACT OUR OFFICE BELOW OR VISIT OUR WEB PAGE: <http://www.fsifilters.com>.



® 100 Anchor Road
 P.O. Box 735
 Michigan City, IN 46361
 (219) 879-3307
 (219) 877-0632 FAX

Viton® is a registered trademark of Dupont Dow Elastomers. There are no expressed or implied warranties, including the implied warranty of merchantability and fitness for a particular purpose not specific herein respecting this agreement or the product being sold hereunder or the service provided herein.



PRINTED IN USA