

X100™ CONVERTIBLE FILTER HOUSING

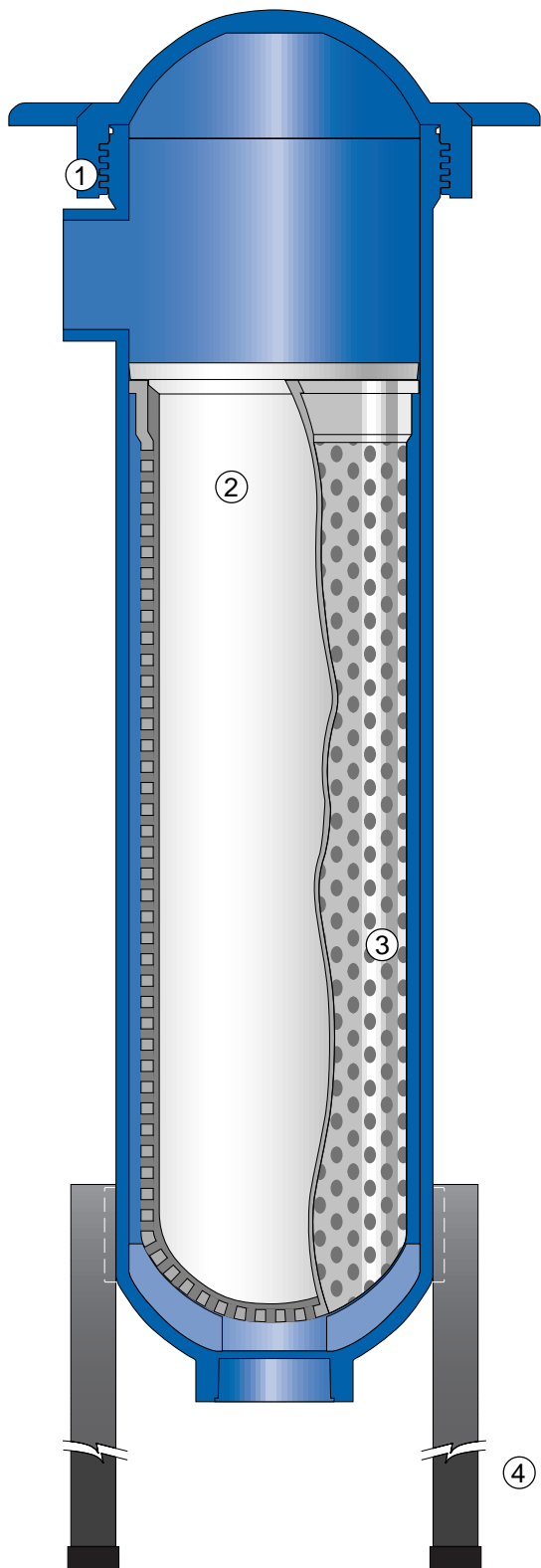

X100B
Bag Filter Housing

Designed to accept either a bag filter or cartridge filter, the **FSI X100™ Convertible Filter Housing** allows you to choose the filter media and construction to precisely fit your needs.

The **X100** is made from light-weight polypropylene to accommodate a wide range of chemical resistance. The “clean walls” provide easy-to-clean internal surfaces and the **X100** features by-pass free sealing. The specially developed lid-gasket enables lid sealing without the need for additional tools.

- ① Threaded Lid
- ② Polyloc® Filter Bag
- ③ Polypropylene Retainer Basket
- ④ Adjustable Support Legs - Full-Length 12”
- ⑤ Polyseal™ Cartridge

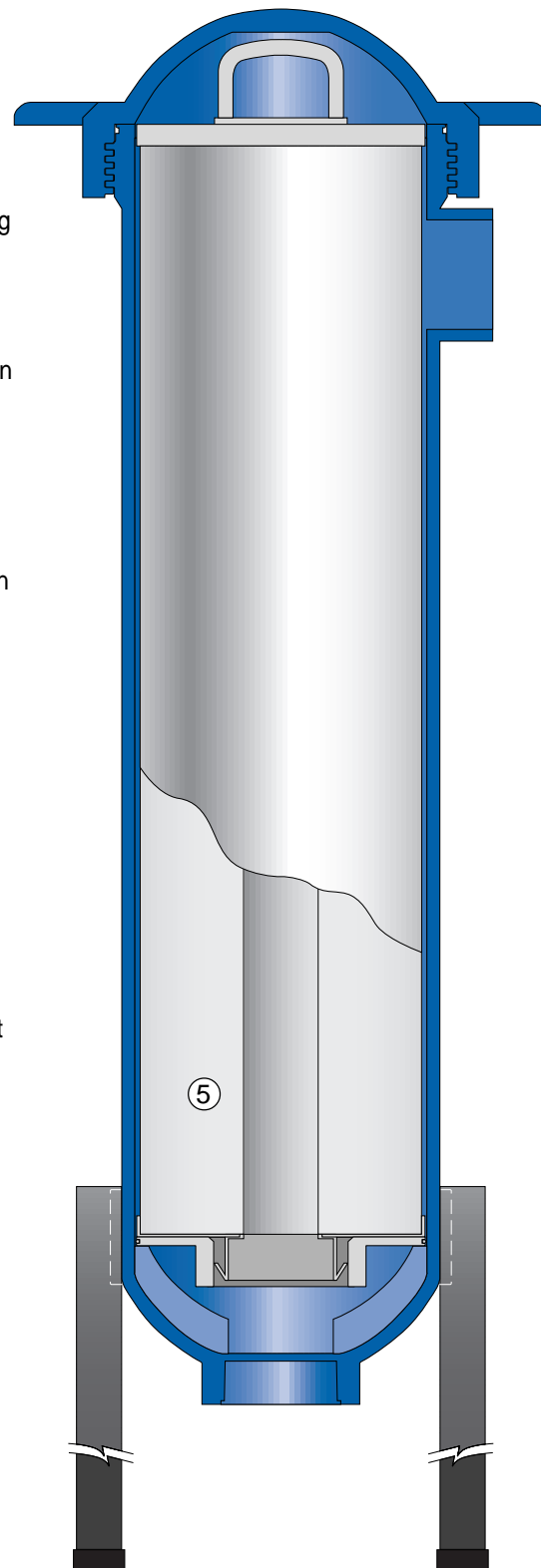

X100C
Cartridge Filter Housing

X01™ FILTER BAG

Measuring 6" in diameter by a length of 20", the X01™ Filter Bag has 2 square feet of surface area (0.186 square meters), making it equivalent to a standard #1 size bag. The X01 is fitted with the patented Polyloc® Ring which seals directly against the wall of the filter housing and eliminates the chance of by-pass.

A heavy duty Polypropylene Restrainer Basket supports the X01. The X01's Polyloc Ring sits directly against the basket collar for additional bag support.

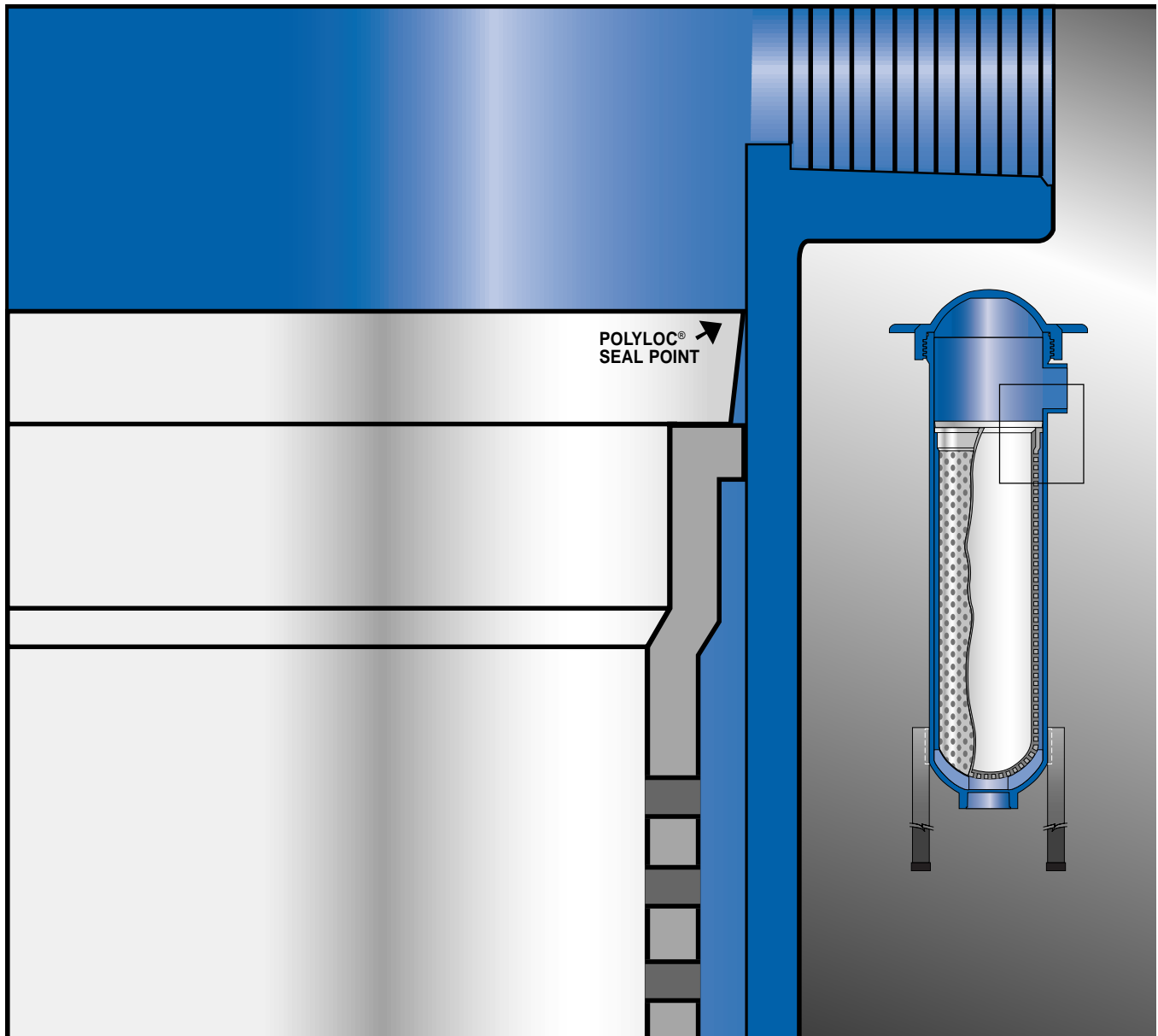

X20 FILTER CARTRIDGE

The X20™ Polyseal™ Cartridge is a steep pore gradient, depth filter designed to have a large dirt loading capacity. The X20 measures 5 1/2 inches in diameter, with a length of 23 1/4 inches, yielding a total cartridge volume of 500 cubic inches. In laboratory tests, the X20 has outperformed standard 10" cartridges by holding 20 times the volume of dirt.

The design of X20 Polyseal Cartridge features a single open-end

that directs fluid from outside the cartridge, in through the filter. A built in handle on the cartridge top assists in seating and removing the X20. The cartridge bottom is equipped with the FSI patented Polyseal End Fitting to ensure by-pass free sealing without the need for double O rings or flat gaskets. The X20 Polyseal Cartridge fits securely into the cartridge plate and does not require springs, hold-down plates or center posts.

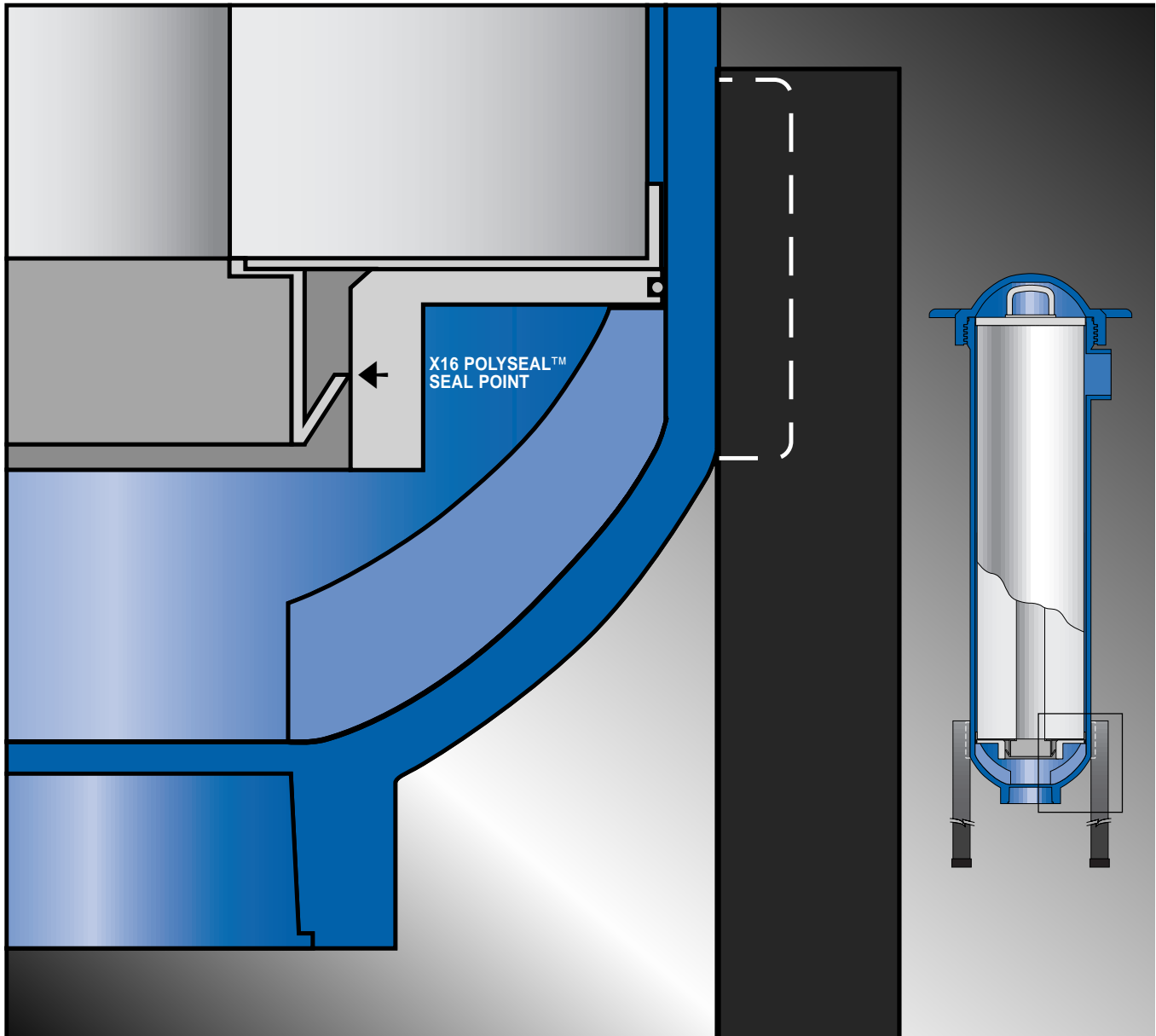

X100™ CONVERTIBLE FILTER HOUSING

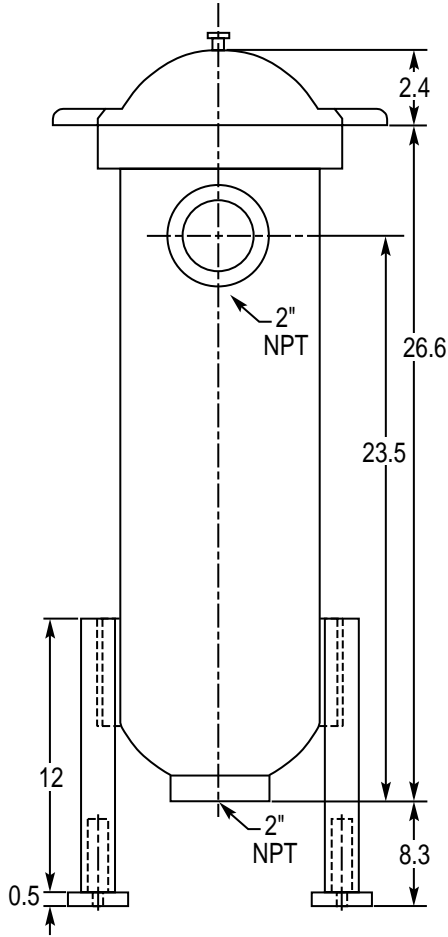

Operating Range for X100 Filter Housing

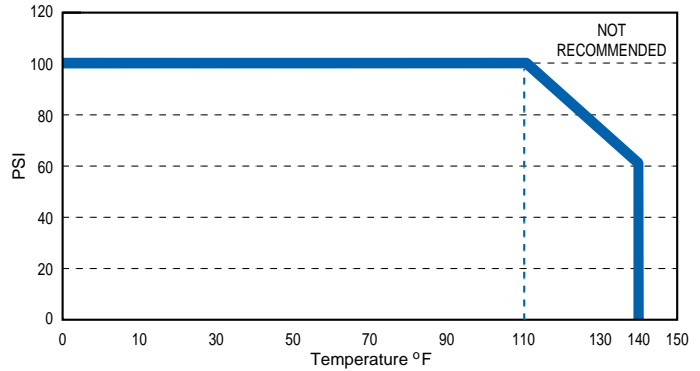

**Clear Water Pressure Drop
FSI BPONG X01 Bags**

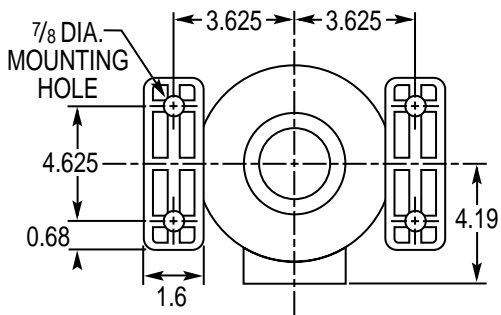
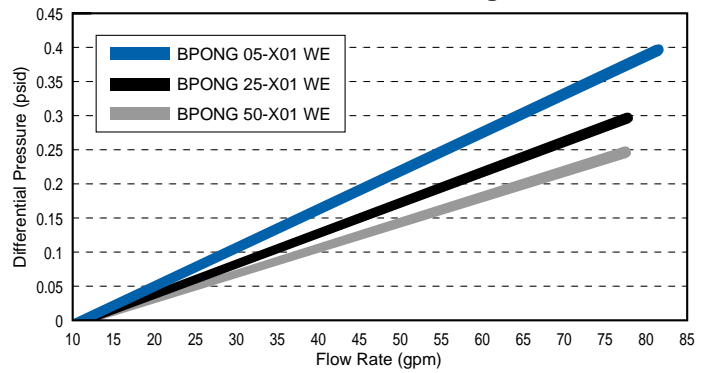

**Clear Water Pressure Drop
FSI X20 Cartridges
5.5" OD 23.25" Length**

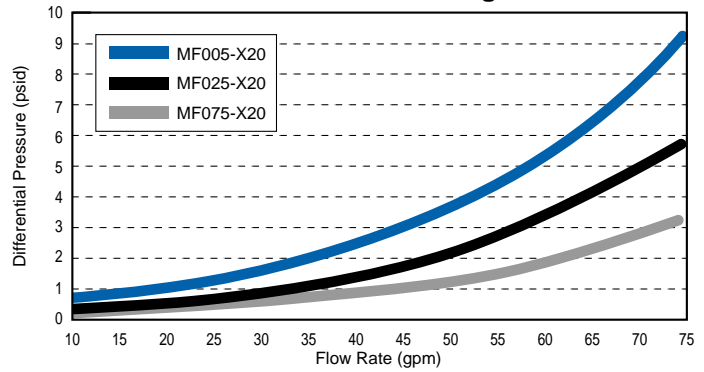

Filter Specialists, Inc.

® 100 Anchor Road
P.O. Box 735
Michigan City, IN 46360
219/879-3307
219/879-0744 Fax
800-348-3205



Printed on
Recycled Paper
In the U.S.A.